

SGV-2-XX-30; SGV-2-XX-50

Pump Dimensions

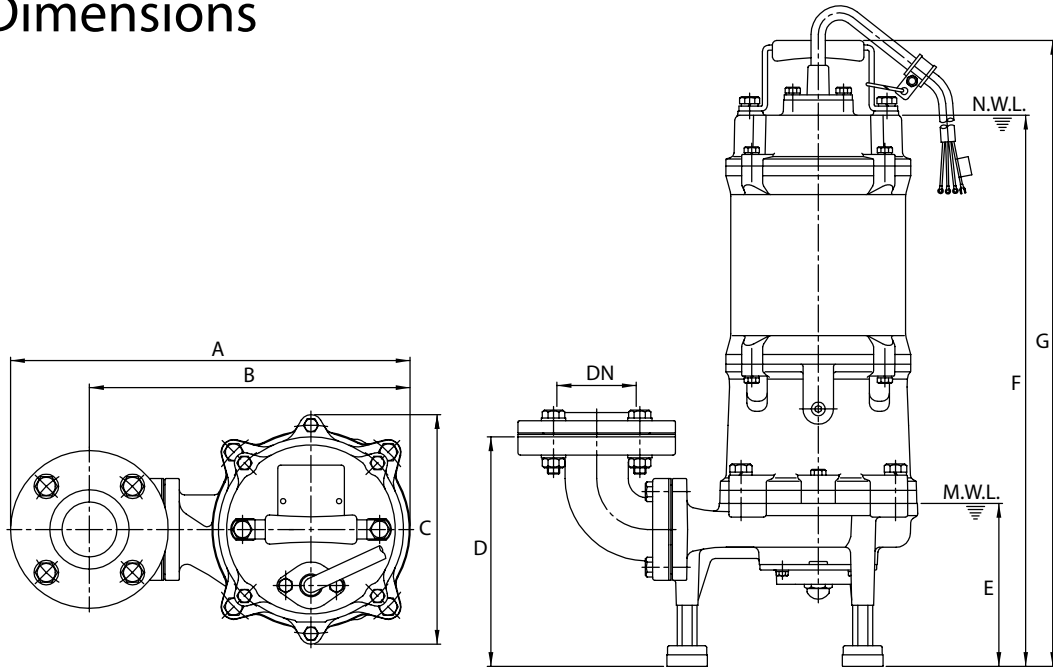

| TYPE        | DN | A     | B     | C    | D    | E    | F     | G     |
|-------------|----|-------|-------|------|------|------|-------|-------|
| SGV-2-XX-30 | 2  | 15.50 | 12.38 | 8.88 | 8.88 | 7.00 | 21.38 | 24.25 |
| SGV-2-XX-50 | 2  | 15.50 | 12.38 | 8.88 | 8.88 | 7.00 | 21.38 | 24.25 |

N.W.L.: Normal water level  
M.W.L.: Minimum water level

Easy Lift GRS - Guide Rail System Dimensions

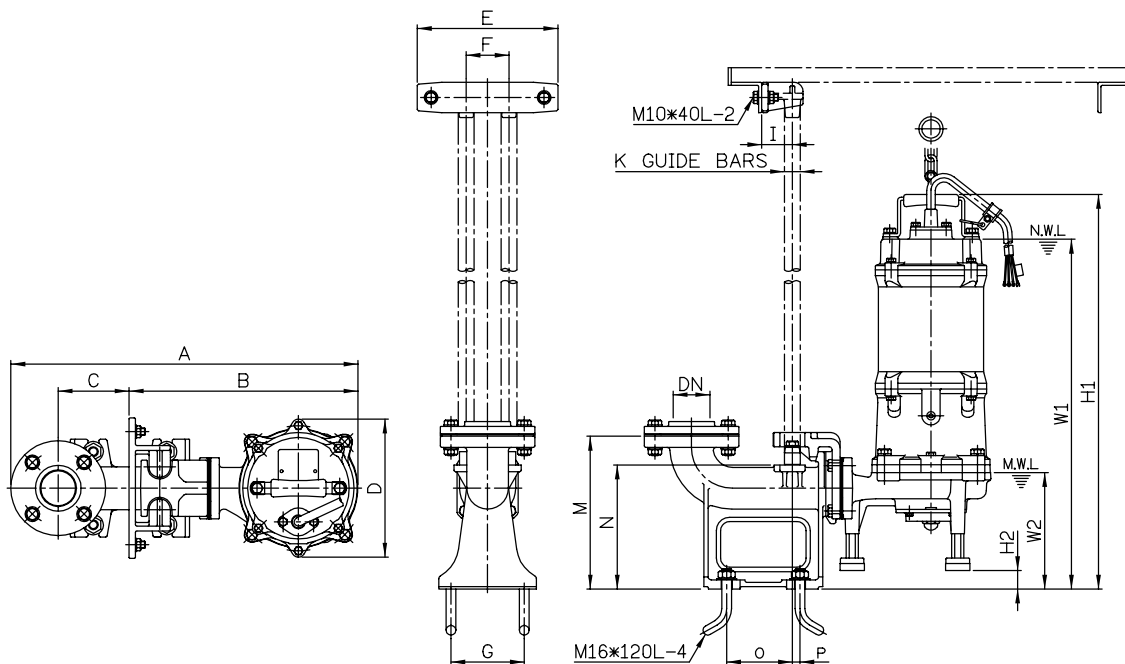

| TYPE        | DN | A     | B     | C    | D    | E    | F    | G    | I    | K    | M    | N    | O    | P    | W1    | W2   | H1    | H2   |
|-------------|----|-------|-------|------|------|------|------|------|------|------|------|------|------|------|-------|------|-------|------|
| SGV-2-XX-30 | 2  | 22.38 | 14.75 | 4.50 | 8.88 | 9.00 | 2.75 | 4.75 | 2.00 | 1.25 | 9.88 | 8.00 | 4.25 | 0.50 | 22.63 | 7.63 | 25.50 | 1.25 |
| SGV-2-XX-50 | 2  | 22.38 | 14.75 | 4.50 | 8.88 | 9.00 | 2.75 | 4.75 | 2.00 | 1.25 | 9.88 | 8.00 | 4.25 | 0.50 | 22.63 | 7.63 | 25.50 | 1.25 |

All dimensions are in inches unless otherwise noted.